

**Agilent 4100
Microwave Plasma
Atomic Emission
Spectrometer**

Site Preparation Guide



Agilent Technologies

Notices

© Agilent Technologies, Inc. 2011

No part of this guide may be reproduced in any form or by any means (including electronic storage and retrieval or translation into a foreign language) without prior agreement and written consent from Agilent Technologies, Inc. as governed by United States and international copyright laws.

Guide Part Number

G8000-90001

Edition

First edition, August 2011

Printed in USA

Agilent products must only be used in the manner described in the Agilent product user guides. Any other use may result in damage to the product or personal injury. Agilent is not responsible for any damages caused, in whole or in part, by improper use of the products, unauthorized alterations, adjustments or modifications to the products, failure to comply with procedures in Agilent product user guides, or use of the products in violation of applicable laws, rules or regulations.

Agilent shall not be liable for errors or damages on products or performance due to using non-Agilent genuine parts.

Warranty

The material contained in this document is provided “as is,” and is subject to being changed, without notice, in future editions. Further, to the maximum extent permitted by applicable law, Agilent disclaims all warranties, either express or implied, with regard to this guide and any information contained herein, including but not limited to the implied warranties of merchantability and fitness for a particular purpose. Agilent shall not be liable for errors or for incidental or consequential damages in connection with the furnishing, use, or performance of this document or of any information contained herein. Should Agilent and the user have a separate written agreement with warranty terms covering the material in this document that conflict with these terms, the warranty terms in the separate agreement shall control.

Technology Licenses

The hardware and/or software described in this document are furnished under a license and may be used or copied only in accordance with the terms of such license.

Restricted Rights Legend

If software is for use in the performance of a U.S. Government prime contract or subcontract, Software is delivered and licensed as “Commercial computer software” as defined in DFAR 252.227-7014 (June 1995), or as a “commercial item” as defined in FAR 2.101(a) or as “Restricted computer software” as defined in FAR 52.227-19 (June 1987) or any equivalent agency regulation or

contract clause. Use, duplication or disclosure of Software is subject to Agilent Technologies’ standard commercial license terms, and non-DOD Departments and Agencies of the U.S. Government will receive no greater than Restricted Rights as defined in FAR 52.227-19(c)(1-2) (June 1987). U.S. Government users will receive no greater than Limited Rights as defined in FAR 52.227-14 (June 1987) or DFAR 252.227-7015 (b)(2) (November 1995), as applicable in any technical data.

Safety Notices

CAUTION

A **CAUTION** notice denotes a hazard. It calls attention to an operating procedure, practice, or the like that, if not correctly performed or adhered to, could result in damage to the product or loss of important data. Do not proceed beyond a **CAUTION** notice until the indicated conditions are fully understood and met.

WARNING

A **WARNING** notice denotes a hazard. It calls attention to an operating procedure, practice, or the like that, if not correctly performed or adhered to, could result in personal injury or death. Do not proceed beyond a **WARNING** notice until the indicated conditions are fully understood and met.

Contents

1. Introduction	7
Installation Guidelines	8
Site Preparation Check-list	9
2. Safety Practices and Hazards	11
General	11
Plasma	12
Heat, Vapors and Fumes	13
Compressed Gas Hazards	14
Electrical Hazards	15
Other Precautions	15
Warning Symbols	16
Color Coding	17
CE Compliance	18
ICES/NMB-001	18
3. Laboratory Environment	19
Suitability	19
Environmental Conditions	20
Temperature control	21
Cleanliness	21
Instrument cooling air supply	21
Workbench	22

Contents

Workbench Location	22
PC Requirements	23
4. Instrument Shipping Information	25
In-house Transit Routes	25
Insurance After Delivery	26
Weights and Dimensions	26
Transit Damage	27
Unpacking the Instrument	28
5. Laboratory Facilities	29
Exhaust System	29
Electrical Power Supplies	30
Electrical requirements	31
Instrument power connections	31
Other electrical connections	32
Fuses	32
Gas Supplies	32
Cylinder storage instructions	34
Cryogenic liquids	34
Waste Fluid Container	35
Guidelines for Software Installation	35

6. Accessories and Options	37
Organic Solvents or Hydrofluoric Acid	37
External Gas Control Module	38
Gas requirements	38
Monochromator Optics Air Purge	39
Gas requirements	40
Sample Preparation System (SPS 3)	40
Environmental conditions	41
Multimode Sample Introduction System (MSIS)	41
Agilent 4107 Nitrogen Generator	42
Environmental requirements	42
Maximum sound power level	42
Gas requirements	43
Electrical requirements	44
Weights and dimensions	44
7. Gas Requirements and Configurations	45
Compressed Air Requirements	45
Agilent 4100 MP-AES Gas Configurations	48

Introduction

This page is intentionally left blank.



1. Introduction

Installation Guidelines	8
Site Preparation Check-list	9

This guide contains the information required to successfully prepare a site for an Agilent 4100 Microwave Plasma Atomic Emission Spectrometer (MP-AES) instrument installation.

On completion of the site preparation, fill in the check-list on Page 9, (striking out those entries not applicable), and send this check-list to your local Agilent agent or Agilent sales and service office. As soon as it is received, Agilent or its agent will contact you to arrange a convenient time for installation.

References to the Agilent 4100 MP-AES instrument are applicable to all models and configurations unless otherwise stated.

In case of difficulty in preparing for the installation, and for details of operator training courses, please contact your Agilent sales representative or field service engineer at the address given below:

Installation Guidelines

Allow a minimum of four hours for the installation by an Agilent field service engineer. If accessories are included, allow a maximum of eight hours.

The installation and familiarization will include the following

- Instrument installation
- Instrument software installation and registration
- Accessory installation
- Instrument installation performance tests
- Basic customer training
- Maintenance overview

Site Preparation Check-list

I have prepared:

- Exhaust system
- Gas supplies
 - Nitrogen (separate supplies for the MP-AES and EGCM)
 - Air (separate supplies for the MP-AES and nitrogen generator)
 - Argon
- Electrical power supplies
- Power connections
- Personal computer with Windows 7 64-bit operating system installed and printer
- Waste container
- Cooling air system (if required)

Accessories

- SPS 3 – Sample Preparation System
- EGCM – External Gas Control Module – including gas supplies
- Monochromator Optics Purge – including gas supplies
- Agilent 4107 Nitrogen Generator – including gas supplies

All preparations have been completed. Please arrange for the installation to be completed as soon as possible. I understand that if the installation site is not prepared in accordance with the enclosed instructions, additional installation charges may be applicable.

Company name and address: _____

Name: _____

Position: _____

Telephone: _____ Date: _____

Preferred Installation date: _____

Signed: _____

Introduction

This page is intentionally left blank.

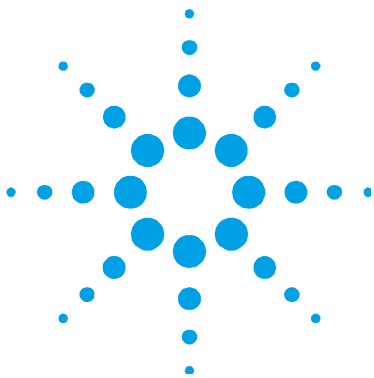

2. Safety Practices and Hazards

General	11
Plasma	12
Heat, Vapors and Fumes	13
Compressed Gas Hazards	14
Electrical Hazards	15
Other Precautions	15
Warning Symbols	16
Color Coding	17
CE Compliance	18
ICES/NMB-001	18

General

Operation of an Agilent 4100 Microwave Plasma Atomic Emission Spectrometer (MP-AES) involves the use of compressed gases, microwave energy and hazardous materials including corrosive fluids and flammable liquids. Careless, improper or unskilled use of this instrument can cause death or serious injury to personnel, and/or severe damage to equipment and property. Only trained personnel should use this equipment.

The MP-AES incorporates interlocks and covers that are designed to prevent inadvertent contact with any potential hazards. If the MP-AES is used in any manner not specified by Agilent, this protection may be impaired. It is good practice to develop safe working habits that do not depend upon the correct operation of the interlocks for safe operation. It is essential that no interlock or cover is bypassed, damaged or removed.

The safety practices described below are provided to help the user operate the Agilent 4100 MP-AES safely. Read each safety topic thoroughly before attempting to operate the MP-AES and *always* operate the MP-AES in accordance with these safety practices.

If you are unsure of the effects of any liquid, gas or chemical on the MP-AES, consult your Agilent field service engineer or approved representative before use.

If the MP-AES is to be used in conjunction with other non-Agilent equipment, the safety requirements of any system incorporating the MP-AES is the responsibility of the assembler of the system.

Plasma

The plasma is extremely hot (about 6,000 °C, 11,000 °F) and operates using high levels of microwave energy. The plasma emits high intensity light. Always wear appropriate eye protection if viewing the plasma. Close contact with the operating plasma can result in severe heat burns to the skin, and exposure to microwave radiation can cause sub-surface skin burns.

Do *not* operate the plasma if:

- the microwave excitation assembly appears to be damaged
- foreign material is present in the viewing port (left end of the microwave excitation assembly) or the torch aperture (vertical space for the torch)
- the space above the chimney is not clear of objects
- the MP-AES exhaust system is not connected or turned on

The microwave excitation assembly is designed to contain microwave radiation and generate the plasma while still permitting easy installation of the torch and viewing of the plasma. The MP-AES has an interlock system that is designed to extinguish the plasma if either the pre-optics window holder is opened or the torch is unloaded. Do *not* attempt to bypass the interlock system.

Before opening the pre-optics window holder or unloading the torch, extinguish the plasma by:

- pressing SHIFT and F5 on the keyboard
- selecting the 'Plasma off' option from the 'Plasma' drop-down arrow on the MP Expert software toolbar
- pressing the Plasma Enable switch on the front of the Agilent 4100 MP-AES

The torch remains hot for up to five minutes after the plasma is extinguished. Touching this area before it has cooled sufficiently may result in burns. Allow the torch to cool before removing it from the loader.

The plasma system has been carefully designed to operate safely and effectively when using torches and related components that conform to Agilent's design criteria. Use of non-approved components in the MP-AES may render the system inoperative and/or hazardous. It may also invalidate the warranty on the MP-AES. Use only torches and related components supplied or authorized by Agilent.

Heat, Vapors and Fumes

Heat, ozone, vapors and fumes generated by the plasma can be hazardous, and must be extracted from the MP-AES by means of an exhaust system. Ensure that an exhaust system of the appropriate type is fitted and operational (as specified in the site preparation guide). The system must be vented to the outside in accordance with local regulations and never within the building. Regularly check the exhaust system by smoke test to ensure that the exhaust system is functioning correctly. The exhaust fan must always be switched on *before* igniting the plasma.

Compressed Gas Hazards

All compressed gases (other than air) can create a hazard if they leak into the atmosphere. Even small leaks in gas supply systems can be dangerous. Any leak (except that of air) can result in an oxygen-deficient atmosphere which can cause asphyxiation. The storage area must be adequately ventilated and must comply with the rules and regulations imposed by the local authorities responsible for such use in the workplace.

Gas cylinders must be stored and handled strictly in accordance with local safety codes and regulations. Cylinders must be used and stored only in a vertical position and secured to an immovable structure or a properly constructed cylinder stand. Move cylinders only by securing them to a properly constructed trolley.

If gases are to be plumbed from a remote storage area to the instrument site, ensure that the local outlets are fitted with stop valves, pressure gauges and suitable regulators that are easily accessible to the instrument operator. The gas outlets must be provided within 1.5 meters (5 feet) of the Agilent 4100 MP-AES.

Use only approved regulator and hose connectors (refer to the gas supplier's instructions). Keep gas cylinders cool and properly labeled. (All cylinders are fitted with a pressure relief device that will rupture and empty the cylinder if the internal pressure is raised above the safe limit by excessive temperatures.) Ensure that you have the correct cylinder before connecting it to the MP-AES.

If using cryogenic (liquid) gases (for example, liquid nitrogen or argon) prevent severe burns by wearing suitable protective clothing and gloves.

Electrical Hazards

The Agilent 4100 MP-AES and some accessories contain electrical circuits, devices and components operating at dangerous voltages. Contact with these circuits, devices and components can cause death, serious injury or painful electric shock. Panels or covers that are retained by screws on the MP-AES and accessories may be opened *only* by Agilent-trained, Agilent-qualified or Agilent-approved field service engineers (unless specifically instructed). Consult the documentation or product labels supplied with your personal computer (PC), monitor and printer to determine which parts are operator-accessible.

Other Precautions

Use of the MP-AES and accessories may involve materials, solvents and solutions that are flammable, corrosive, toxic or otherwise hazardous. Careless, improper or unskilled use of such materials, solvents and solutions can create explosion hazards, fire hazards, toxicity and other hazards that can result in death, serious personal injury or damage to equipment.

Always ensure that laboratory safety practices governing the use, handling and disposal of hazardous materials are strictly observed. These safety practices should include wearing appropriate safety clothing and safety glasses.

Air flow to the MP-AES and accessories must be unobstructed. Do not block the ventilation grill on the instrument. Consult the documentation supplied with your PC, monitor and printer for their specific ventilation requirements.

Great care should be taken when working with glass or quartz parts to prevent breakage and cuts. This is especially important when attaching plastic tubing to glass barbs, or removing and replacing pieces of broken torch.

The MP-AES weighs approximately 73 kg (161 lb). To avoid injury to personnel or damage to the MP-AES or property, always use a forklift or other suitable mechanical lifting device to move the MP-AES.

Use only Agilent-supplied spares with your MP-AES.

Warning Symbols

The following is a list of symbols that appear in conjunction with warnings in this guide and on the Agilent 4100 MP-AES. The hazard they describe is also shown. The beginning of the warning text is noted by a warning icon:

WARNING

A triangular symbol indicates a warning. The meanings of the symbols that may appear alongside warnings in the documentation or on the MP-AES itself are as follows:



Corrosive liquids



Electrical shock



Eye hazard



Fire hazard



*Heavy weight
(danger to feet)*



*Heavy weight
(danger to hands)*



Hot surface



Moving parts



Non-ionizing radiation



Noxious gases







Sharp object

The following symbol may be used on warning labels attached to the MP-AES. When you see this symbol, refer to the relevant operation or service documentation for the correct procedure referred to by that warning label.



The following symbols appear on the Agilent 4100 MP-AES for your information.

	Mains power on
	Mains power off
	Single phase alternating current
	When attached to the rear of the instrument, it indicates that the product complies with the requirements of one or more EU directives.

Color Coding

The various indicator lights appearing on Agilent instruments and associated accessories are color coded to represent the status of the instrument or accessory.

- A green light indicates the instrument is in normal/standby mode.
- An orange light indicates that a potential hazard is present.
- A blue light indicates that operator intervention is required.
- A red light warns of danger or an emergency.

CE Compliance

Your Agilent 4100 MP-AES has been designed to comply with the requirements of the Electromagnetic Compatibility (EMC) Directive and the Low Voltage (electrical safety) Directive (commonly referred to as the LVD) of the European Union. Agilent has confirmed that each product complies with the relevant Directives by testing a prototype against the prescribed EN (European Norm) standards.

Proof that a product complies with these directives is indicated by:

- the CE Marking appearing on the rear of the product, and
- the documentation package that accompanies the product containing a copy of the Declaration of Conformity. The Declaration of Conformity is the legal declaration by Agilent that the product complies with the directives listed above, and shows the EN standards to which the product was tested to demonstrate compliance.

ICES/NMB-001

This ISM device complies with Canadian ICES- 001.

Cet appareil ISM est conforme à la norme NMB-001 du Canada.



3. Laboratory Environment

Suitability	19
Environmental Conditions	20
Temperature control	21
Cleanliness	21
Instrument cooling air supply	21
Workbench	22
Workbench Location	22
PC Requirements	23

This section includes information on laboratory requirements for the Agilent 4100 MP-AES instrument including:

- Environmental conditions
- Workbench construction and location
- Guidelines for software installation

Suitability

The instrument is *only* suitable for indoor use and is classified suitable under the following categories (EN 61010-1):

- Installation category II
- Pollution degree 2
- Equipment class I

Environmental Conditions

The area selected for the operation of an Agilent 4100 MP-AES instrument must be free from drafts, corrosive atmospheres and vibration. Sample preparation areas and materials storage facilities should be located in a separate room.

The area should be a dust free, low humidity environment. Air-conditioning is strongly recommended for control of the environment.

Table 1. Suitable environmental conditions

Condition	Altitude	Temp (°C)	Humidity (%RH) non-condensing	Max Rate Of Change (°C)
Non-operating (Transport)	0–4,000 m (0–13100 ft)	-40–70 °C (-40–158 °F)	<90	
Operating and complying with performance specifications	0–3,000 m (0–9,800 ft)	5–35 °C (41–95 °F)	50–80	≤ 2 °C /hr ≤±10°C since calibration
	3,000–4,000 m (9,800–13,100 ft)	5–25 °C (41–77 °F)	50–80	≤ 2 °C /hr ≤±10 °C since calibration

NOTE

For optimum analytical performance, it is recommended that the ambient temperature of the laboratory be between 20–25 °C (68–77 °F). The ambient temperature *must* be constant, with the maximum acceptable temperature change being 2 °C (3.6 °F) per hour to comply with performance specifications. The maximum temperature change before a recalibration is required is ±10 °C (±18 °F).

Temperature control

Most of the heat generated by the Agilent 4100 MP-AES instrument into the laboratory is extracted from the laboratory by the exhaust system. When the plasma is operating, approximately 200 W of heat from the instrument electronics flows into the laboratory.

Cleanliness

Limit dust levels to less than 36,000,000 particles (0.5 microns or larger) per cubic meter of air. This is equivalent to a very clean office.

Instrument cooling air supply

The Agilent 4100 MP-AES instrument requires clean, dry, oil-free non-corrosive air for cooling purposes. This is supplied to the instrument through an air inlet vent located at the top, rear of the instrument. The vent is fitted with a dust filter, to filter out large particulate matter from the surrounding environment.

The air supply is used to cool the internal mechanical and electronic components of the instrument. Several of these assemblies contain parts prone to corrosion. The introduction of cooling air contaminated with high levels of acid vapor or other corrosive substances may cause damage to the instrument.

For laboratories where sample preparation facilities are in the same area or where the lab environment is contaminated with acid vapor or other corrosive substances, an external cooling air supply to the instrument must be provided. The cooling air should be supplied from an environmentally controlled area that is away from the instrument exhaust and any other area where corrosive materials are stored or used.

The cooling air system with flue, fan and ducting must provide a minimum positive flow of 3 m³/min (106 cfm). The ducting should be corrosion resistant and fire-proof.

Workbench

The Agilent 4100 MP-AES is a precision optical instrument. Do not subject the instrument to impact shock. The workbench must be free from vibration and must be stable and strong enough to support the total weight of the equipment to be placed on top of the workbench. The bench top should be large enough to permit free circulation of air through the main instrument and around each of the accessories.

The information provided in the weights and dimensions table will help make planning easier. Mobile or semi-permanent trolleys can be used as workbenches for the instrument, but you must lock the wheels. The PC, printer and accessories such as the Sample Preparation System 3 (SPS 3) can be positioned on a trolley. A specially designed SPS 3 trolley is available from Agilent (part number 9910027800).

To avoid damage through spillage of samples being used, the instrument bench top should be covered with a material which is corrosion resistant and impervious to liquid spillage. For comfortable working conditions and easy access to the instrument sample introduction system, the height of the workbench should be approximately 900 mm (36 in).

Workbench Location

The workbench location should permit service access from the front and right side of the instrument. A minimum of 400 mm (16 in) free space at the sides of the instrument and 100 mm (4 in) at the rear is required for maintenance and service access.

Position the instrument on the bench to allow easy access to the power switch located on the right side of the instrument.

The Agilent 4100 MP-AES instrument should not be located close to an access door, window or any other area where drafts may cause unstable temperature conditions.

PC Requirements

The minimum configuration represents the absolute minimum you can run the software on. This PC configuration may be out of manufacture, but you may want to use a PC you already have. The recommended configuration is that which you would buy new.

Table 2. PC requirements

Minimum	Recommended
1 GHz 64-bit (x86) dual core processor or higher	2 GHz 64-bit (x86) quad core processor or higher
2 GB of system memory	2 GB of system memory
40 GB hard drive with at least 15 GB of available space	200 GB hard drive
DVD-ROM Drive	DVD-ROM Drive
Screen resolution of 1280x768 running in 96 dpi	19 in screen with minimum screen resolution of 1280x768 running in 96 dpi
One USB connector	One USB connector
Windows 7 Professional 64-bit	Windows 7 Professional 64-bit

Higher rated PC components can be substituted for those listed above, for example, processor type, amount of memory, screen size and resolution, etc.

Laboratory Environment

This page is intentionally left blank.

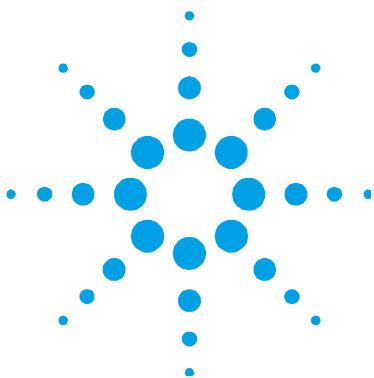

4. Instrument Shipping Information

In-house Transit Routes	25
Insurance After Delivery	26
Weights and Dimensions	26
Transit Damage	27
Unpacking the Instrument	28

Generally, the Agilent 4100 MP-AES instruments are sold *Free On Board* shipping point, with transportation from this point at the customer's expense. Due to the size and nature of the instrument, it is advisable that a third party is engaged to assist with transportation from the point of unloading to the final placement of the instrument in the laboratory. The Agilent Field Sales and Service offices will be able to assist in recommending a third party that specializes in the transportation of precision scientific instrumentation.

NOTE

The Agilent field service engineer must be present during the unpacking of the instrument.

In-house Transit Routes

In-house transit routes must be carefully considered. Vertical, horizontal and turning clearances should be calculated from the shipping crate dimensions of the instrument, which is the largest unit in any system arrangement.

Particular attention should be made to the clearance of any doors in the transit route to the laboratory. The required turning and door clearance may need to take into consideration any lifting device used for transporting the instrument such as a fork lift, pallet truck or trolley.

Insurance After Delivery

As the carrier’s liability ceases when the equipment is delivered, Agilent recommends that the instrument owner arranges separate insurance that will cover transportation from the delivery point to the installation site. The delivery point will vary according to the carrier, the shipping method, and in some cases the terms of sale. Some carriers will only deliver to their own distribution center, while others may deliver to the actual installation site.

Weights and Dimensions

Table 3. Weights and dimensions

System unit	Width	Depth	Height	Weight
Agilent 4100 MP-AES	960 mm (37.8 in)	660 mm (26.0 in)	660 mm (26.0 in)	73 kg (161 lb)
Shipping dimensions	1170 mm (46.0 in)	815 mm (32.0 in)	980 mm (38.6 in)	100 kg (220 lb)
SPS 3	490 mm (19.3 in)	285 mm (11.2 in)	510 mm (20.1 in)	15 kg (33.1 lb)
Shipping dimensions	760 mm (29.9 in)	500 mm (19.7 in)	840 mm (33.1 in)	31 kg (68.4 lb)
SPS trolley	580 mm (23 in)	412 mm (17 in)	400 mm (16 in)	
Agilent 4107 Nitrogen Generator	400 mm 15.7 in	480 mm 18.9 in	840 mm 33.0 in	110 kg 242.5 lb
Shipping dimensions	700 mm 27.6 in	700 mm 27.6 in	1,070 mm 42.1 in	130 kg 286.6 lb

WARNING



Heavy Weight

The Agilent 4100 MP-AES instrument weighs approximately 73 kg (161 lb). To avoid injury to personnel or damage to equipment, always use a suitable lifting device when moving the instrument.

WARNING**Heavy Weight**

The Agilent 4107 Nitrogen Generator weighs approximately 110 kg (242.5 lb). To avoid injury to personnel or damage to equipment, always use a suitable lifting device when moving the instrument.

Transit Damage

Transit damage can be obvious or concealed, and in either case will only be admitted by the carrier if it is reported as agreed in the terms of their agreement. For any claims against damage in transit, the following general rules apply.

- Before accepting delivery, you should inspect the packages for signs of obvious damage. The nature of any obvious damage must be noted on the carrier's waybill, and then must be countersigned by a representative of the carrier.
- Within the time limits stated in the terms of conditions of carriage, a further inspection must be made for concealed damage. If any damage is found at this stage, the carrier must be notified in writing and all packaging material must be retained for subsequent inspection by a representative of the carrier.
- A copy of any damage report must be forwarded to the Agilent Sales Office dealing with the supply of the equipment.

Agilent 4100 MP-AES instruments are inherently robust, and the packaging is designed to prevent damage. It must be remembered that the contents form part of a precision measuring system and all packages should be handled accordingly. In transit, sharp jolts and shocks must be avoided and the packages must not be inverted or tilted unnecessarily. Markings on the shipping cartons generally indicate the required orientation of the carton.

Unpacking the Instrument

NOTE

The Agilent field service engineer must be present during the unpacking of the instrument.

WARNING



Heavy Weight

The Agilent 4100 MP-AES instrument weighs approximately 73 kg (161 lb). To avoid injury to personnel or damage to equipment, always use a suitable lifting device when moving the instrument.

Once the instrument has been delivered to the installation site and the site preparation checklist is complete, contact your Agilent office to arrange installation.

For site preparation information for your Agilent 4107 Nitrogen Generator, see Page 42.

WARNING



Shock Hazard

To prevent death or personnel injury from accidental contact with high voltages within the instrument do not remove any of the instrument covers. Do not connect the instrument to the mains supply.

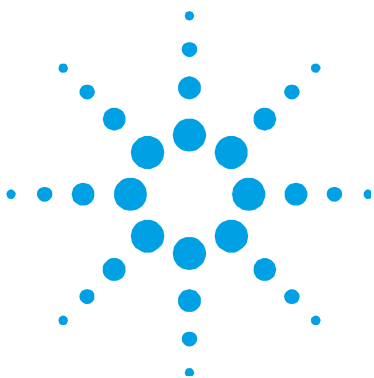

5. Laboratory Facilities

Exhaust System	29
Electrical Power Supplies	30
Electrical requirements	31
Instrument power connections	31
Other electrical connections	32
Fuses	32
Gas Supplies	32
Cylinder storage instructions	34
Cryogenic liquids	34
Waste Fluid Container	35
Guidelines for Software Installation	35

This section includes information on the laboratory facilities required to support the operation of the instrument.

Exhaust System

The plasma operates at a temperature of approximately 6,000 °C, (11,000 °F) with up to 1,000 Watts of power (6,480 kilojoules per hour). The instrument exhaust fumes can be noxious or corrosive.

The Agilent 4100 MP-AES instrument chimney must be connected to an exhaust system. The exhaust system must include an exhaust fan, be ducted to an external vent and provide a minimum flow of 3 m³/min (106 cfm) at the intake point.

The exhaust system installation must comply with any rules and/or regulations that may be imposed by the local authorities responsible for control of facilities and fixtures in the work place.

The exhaust fan should be located at least 2 meters (6 ft 6 in) away from the top of the instrument chimney. The fan control switch and running indicator lamp should be located in a position where the instrument operator can view the indicator and access the control switch.

Ducting must be corrosion resistant, fireproof and should be kept clear of fire alarms, sprinkler heads and other heat sensitive devices.

The external vent must be fitted with a back draft damper and the outlet location must be clear of doors, windows and heater or air-conditioning units.

Electrical Power Supplies

The installation of electrical power supplies must comply with the rules and/or regulations imposed by the local authorities responsible for the use of electrical energy in the workplace.

All power supplies for the Agilent 4100 MP-AES instrument and its accessories should be single phase, AC, 3 wire systems (active, neutral, ground or two active and ground). Each connection should be terminated at an appropriate receptacle within reach of each assembly's power cable. Use of power boards or extension cables is *not* recommended.

Avoid using power supplies from a source that may be subject to electrical interference from other services (such as large electric motors, elevators, welders and air conditioning units).

The Agilent 4100 MP-AES instrument is supplied with a 2 meter long (6 ft 6 in), mains supply cable. The power cable is rated to 10 A/250 V and terminated as indicated in Table 5.

Electrical requirements

Table 4. System electrical specifications

System unit	Required supply voltage	Nominal rating
4100 MP-AES	200–240 V AC $\pm 10\%$ Frequency 50–60 Hz ± 1 Hz	2.04 kVA
SPS 3 autosampler	96–264 V AC 50–60 ± 1 Hz	~220 VA
Personal computer (Typical)	115, 120, 220, 240 V AC, 50/60 Hz	300 VA
Printer (Typical)	115, 120, 220, 240 V AC, 50/60 Hz	85 VA

Instrument power connections

Table 5. Instrument power connections

Power supply phase	Single	
Cable rating	10 A/250 V AC	
	Equipment end	Supply end
Australia	IEC-60320-C13	AS/NZS-3112 10 A 3 pins
USA	IEC-60320-C13	NEMA 6-15P
Europe	IEC-60320-C13	CEE 7/7

Other electrical connections

USB

NOTE

Basic insulation is provided for single fault protection on the USB connector.

Fuses

1CB1 Circuit breaker 12 A fast trip

NOTE

For safety reasons, any other internal fuse or circuit breaker is not operator accessible, and should only be replaced by Agilent-authorized personnel.

Gas Supplies

The installation of compressed or liquid gas supplies must comply with the rules and/or regulations imposed by the local authorities responsible for such use in the workplace.

Depending on the instrument configuration and accessories, up to five different gas supplies are required such as nitrogen and argon for plasma generation, nitrogen for purging and air for the nitrogen generator and for some accessories.

Table 6. Gas specifications at instrument connections

	Argon	Nitrogen	Compressed air Nitrogen generator	Compressed air POP and Accessories (EGCM, Mono Air Purge)
Purity	99.0 %	99.5 % 99.95% for N ₂ mono purge	n/a	n/a
Oxygen		<0.5 % <0.05% for N ₂ mono purge	n/a	n/a
Water vapor		<4 ppm	n/a	n/a
Quality			ISO 8573-1:2010 CLASS 8.4.3	ISO 8573-1:2010 CLASS 1.4.3
Permissible pressure range	200–440 kPa (29–63 psi)	450–600 kPa (65–87 psi)	Nitrogen Generator : 620–750 kPa (90–109 psi)	POP Gas, EGCM/Mono Air Purge : 450–600 kPa (65–87 psi)
Recommended regulated supply pressure	210 kPa (30 psi)	500 kPa (72.5 psi)	620 kPa (90 psi)	500 kPa (72.5 psi)
Required flow rates	1.5 SLPM	Plasma Gas : 25 SLPM N ₂ Mono Purge : 10 SLPM	115 SLPM	POP Gas : 25 SLPM Organics Analysis : 1.5 SLPM, Mono Air Purge : 10 SLPM

The Agilent 4100 MP-AES instrument gas connections are fitted with 1/4 in Swagelok hardware.

Cylinder storage instructions

Cylinders containing gas under pressure should be firmly secured to a rigid structure, and the storage area must be adequately ventilated.

Never locate gas cylinders in a position that is subject to direct heat. Gas storage cylinders often incorporate a pressure release device which will discharge the gas at a predetermined temperature, usually around 52 °C (125 °F).

If gases are to be plumbed from a remote storage area to the instrument site, ensure that the local outlets are fitted with stop valves, pressure gauges and suitable regulators which are easily accessible to the instrument operator. The gas outlets must be provided within 1.5 meters (5 feet) of the instrument.

Cryogenic liquids

Cryogenic liquid gases are stored under pressure at very low temperatures in Portable Liquid Cylinders (PLC).

WARNING**Extreme Cold**

Contact with the super-cold liquid, gas or pipe surfaces can cause severe skin damage. The Portable Liquid Cylinders should be located in a shielded position, and all piping should be routed or covered to prevent skin contact.

For high gas flow rates and/or low ambient temperatures, it may be necessary to obtain sufficient gas pressure by passing the liquid through an external evaporator rather than use the internal pressure building facility of the PLCs.

Liquid argon and liquid nitrogen may *not* be stored for extended periods and often have special storage requirements. Contact your local authorities and cryogenic gas supplier for more detailed information on storage requirements and boil-off rates for local types of PLCs.

Waste Fluid Container

Operation of the Agilent 4100 MP-AES instrument requires the use of a drain vessel for the disposal of excess fluids and vapors from the spray chamber. Suitable tubing is supplied with the instrument for use with inorganic solvents. When using organic solvents, different drain tubing that is suitable for the solvent in use will be required.

A chemically inert container, not glass, to hold minimum of two liters (4 pints) of waste must be provided by the instrument user. It should be located underneath the sample area (or on the right hand side of the instrument), where it is protected by the bench and in full view of the operator.

Guidelines for Software Installation

Agilent recommends that you purchase a PC as part of the Agilent 4100 MP-AES instrument package. The PC included in the package will come with the appropriate operating system as loaded by the PC supplier.

For instructions on installing the Windows operating system, please refer to the appropriate documentation supplied with the software. It is the responsibility of the customer to ensure that the operating system software has been installed and is functional if the customer is supplying the PC or the operating system.

NOTE

Agilent will not assume responsibility for loss of data.

The Agilent service engineer will connect the PC to the instrument and any factory-approved accessories purchased at installation. Initial instrument software installation and familiarization is also included as part of the system installation. For information on installing the MP Expert software, consult the Agilent 4100 MP-AES User's Guide provided with the instrument.

This page is intentionally left blank.

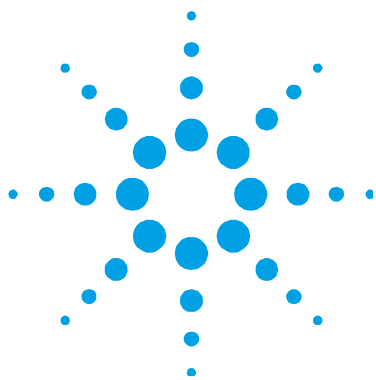

6. Accessories and Options

Organic Solvents or Hydrofluoric Acid	37
External Gas Control Module	38
Monochromator Optics Air Purge	39
Sample Preparation System (SPS 3)	40
Multimode Sample Introduction System (MSIS)	41
Agilent 4107 Nitrogen Generator	42

This section includes site preparation information on Agilent manufactured accessories suitable for use with Agilent 4100 MP-AES. The following information should be used to supplement the documentation included with each accessory.

Organic Solvents or Hydrofluoric Acid

If organic solvents or hydrofluoric acid are intended to be used, then special organic resistant pump tubing is highly recommended.

For analysis of hydrogen fluoride (HF) containing solutions, a purpose designed Ezyfit plasma torch with ceramic injector and specialized sample introduction system consisting of polymer nebulizer and spray chamber are required.

Please refer to the Agilent website for details and part number information: <http://www.chem.agilent.com/>

NOTE

The special fittings supplied for use with organic solvents and hydrofluoric acid may not be suitable for acidic or alkaline solvents. The standard (originally supplied) components should be retained for use in these applications.

External Gas Control Module

(Part number G8000-63005)

The External Gas Control Module (EGCM) has two specific functions:

- 1 Supply nitrogen gas to purge the optics system for determinations of sulfur.
- 2 Introduce a small amount of air into the plasma for the analysis of volatile organics.

The air facilitates the analysis of organics by MP techniques by reducing carbon build-up and background signal resulting in lower detection limits when analyzing organic solutions.

The EGCM can be used in conjunction with a cooled spraychamber. This allows you to analyze directly, without dilution, organic solutions with a high vapor pressure at room temperature (for example, gasoline, naphtha). Cooling the sample prevents high vapor pressures being generated in the spray chamber which can cause back pressure in the chamber, destabilizing the plasma and suppressing the analytical signal.

Gas requirements

All gas supply installations must comply with rules and/or regulations that are imposed by the local authorities responsible for the use of compressed gas in the workplace.

Table 7. ECGM Gas specifications

	Nitrogen	Air
Purity	99.95 %	n/a
Oxygen	< 0.05 %	n/a
Water vapor	< 4 ppm	n/a
Quality	n/a	ISO 8573-1:2010 CLASS 1.4.3
Permissible pressure range	450–600 kPa (65–87 psi)	450–600 kPa (65–87 psi)
Recommended pressure	500 kPa (72.5 psi)	600 kPa (87 psi)
Required flow rates	10 SLPM	1.5 SLPM

NOTE

A nitrogen generator may be used to supply nitrogen to the ECGM. However, it must be a separate unit from that used for the instrument.

Monochromator Optics Air Purge

(Part number G8000-68001)

The monochromator is a precision mechanical device and its continued stable and reproducible operation relies on clean corrosion free surfaces.

The Monochromator Optics Air Purge accessory is designed to minimize the ingress of particles and corrosive vapors, commonly encountered in the typical laboratory, into the monochromator by providing a continuous flow of clean, dry, oil-free and dust free air into the monochromator assembly. The use of this accessory provides additional protection for your instrument.

Gas requirements

All gas supply installations must comply with rules and/or regulations that are imposed by the local authorities responsible for the use of compressed gas in the workplace.

Table 8 Monochromator Optics Air Purge

	Air
Quality	ISO 8573-1:2010 CLASS 1.4.3
Permissible pressure range	450–600 kPa (58–87 psi)
Recommended pressure	600 kPa (87 psi)
Required flow rates	10 SLPM

NOTE

Failure to use the specified air quality will significantly may result in malfunction or damage to the 4100 MP-AES.

Sample Preparation System (SPS 3)

The Agilent Sample Preparation System 3 (SPS 3) is compatible with a wide range of commercially available low-cost autoclavable sample racks.

Sample contamination from airborne particles is eliminated and corrosive or toxic fumes are removed during sampling with the optional environmental enclosure.

Environmental conditions

The SPS 3 accessory is suitable *only* for indoor use. The site should be selected to avoid dusty or corrosive atmospheres.

NOTE

Extra maintenance may be required on the SPS 3 if it is operated in excessively dusty or corrosive conditions.

An Agilent supplied trolley is available for the SPS 3 for purchase (part number 9910056300). A drain vessel must also be accommodated.

Multimode Sample Introduction System (MSIS)

(Part number G8000-63003)

The MSIS, Multimode Sample Introduction System, provides the ability to nebulize liquid samples and create volatile hydrides for introduction to the plasma in one sample introduction system. It uses the highly efficient, thin-film hydride generation technology for creating hydrides.

The MSIS can be used in any one of three modes, sample nebulization only, hydride generation only and simultaneous nebulization and hydride generation.

Use of this accessory requires installation of the 5-channel peristaltic pump, P/N G8000-63002, and use of the inert OneNeb concentric nebulizer, P/N 2010126900, both available from Agilent.

Agilent 4107 Nitrogen Generator

(Part number G8001A)

The Agilent 4107 Nitrogen Generator uses ‘pressure swing adsorption’ technology to produce high quality N₂ from a feed stream of dry, oil free and dust free compressed air. The process relies on the differential adsorption of oxygen and nitrogen under high pressure conditions. Contaminants such as water, oil, organic compounds and dust irreversibly contaminate the adsorption medium and significantly reduce the effectiveness of the separation process. Contamination of the sorbent material with oil will invalidate the warranty.

An Agilent 4107 Nitrogen Generator can be used as the nitrogen supply for the Agilent 4100 MP-AES for plasma generation, sample nebulization and transport. It can also be used to generate nitrogen for the EGCM to purge the optics. Due to the different nitrogen gas purities and flow rates required for these two functions, you will need two nitrogen generators, one each for the MP-AES and EGCM. A commercial air compressor of appropriate specification can be used to supply the generator.

Environmental requirements

The instrument is *only* suitable for indoor use and is classified suitable under the following categories (EN 61010-1)

- Installation category II
- Pollution degree 2
- Equipment class I

Maximum sound power level

The maximum sound power level is 75 dBA.

Table 9. Suitable environmental conditions for the Agilent 4107 Nitrogen Gas Generator

Condition	Altitude	Temperature	Humidity (%RH) non-condensing
Non-operating (Transport)	0–4,000 m (0–13,100 ft)	-40–70 °C (-40–158 °F)	< 90
Operating and complying with performance specifications	0–3,000 m (0–9,800 ft)	5–35 °C (41–95 °F)	50–80
	3,000–4,000 m (9,800–13,100 ft)	5–25 °C (41–77 °F)	50–80

Gas requirements

All gas supply installations must comply with rules and/or regulations that are imposed by the local authorities responsible for the use of compressed gas in the workplace.

NOTE

A separate nitrogen generator unit (to the instrument) must be used to supply the nitrogen to the ECGM.

Table 10. Nitrogen generator gas requirements

	Compressed Air Input	Nitrogen Output (Agilent 4100 MP-AES)	Nitrogen Output (EGCM)
Pressure	620–750 kPa. (90–109 psi)	450–600 kPa (65 psi)	450–600 kPa (65 psi)
Flow rate*	115 SLPM (maximum)	25 SLPM (minimum)	10 SLPM (minimum)
Quality	ISO 8573-1:2010 CLASS 8.4.3	Purity >99.5% <0.5% Oxygen	Purity >99.95% <0.05% Oxygen
Connection	G $\frac{1}{4}$ in female outlet must be provided by customer, 2 m hose supplied	$\frac{1}{4}$ in Swagelok connector to suit MP-AES or ECGM	

*The flow rate into the generator is not constant with time; it fluctuates during the pressure swing absorption cycle.

Electrical requirements

All power supplies should be single phase AC, three-wire system (active, neutral, ground or two active and ground) and should be terminated at an appropriate connection receptacle that is within reach of the power cable.

The installation of electrical power supplies must comply with the rules and/or regulations imposed by the local authorities responsible for the use of electrical energy in the workplace.

The Agilent 4107 Nitrogen Gas Generator is supplied with a 2 meter long (6 ft 6 in), mains supply cable. The cable is rated to 15 A/250 V and is terminated as listed in Table 12.

Table 11. Nitrogen generator electrical specifications

System unit	Required supply voltage	Nominal rating
Nitrogen generator	24 V DC $\pm 5\%$	50 W
Plug pack	100–240 V AC $\pm 10\%$ Frequency 47–63 Hz	60 W (Nominal)

Table 12. System electrical specifications

Power supply phase	Single	
	Equipment end	Supply end
Australia	IEC-60320-C13	AS/NZS-3112 10 A 3 pins
USA	IEC-60320-C13	NEMA 5-15P
Europe	IEC-60320-C13	CEE 7/7

Weights and dimensions

See Page 26 for details.



7. Gas Requirements and Configurations

Compressed Air Requirements	45
Agilent 4100 MP-AES Gas Configurations	48

Compressed Air Requirements

It is recommended to consult a professional compressed air supplier to ensure that your compressed air quality meets the ISO requirements. Most basic industrial or domestic installations will not meet these requirements. Using compressed air that does not meet Agilent's specification may result in damage or malfunction of the Agilent 4100 MP-AES or Agilent 4107 Nitrogen Generator.

Two different qualities of compressed air are required for the Agilent 4100 MP-AES.

The air quality for the Agilent 4107 Nitrogen Generator will typically require an oil free compressor followed by a dryer stage to remove water from the compressed air. The Nitrogen Generator is supplied with a regulator/filter assembly to ensure particulate matter is removed.

The compressed air for the pre-optics protection (POP) Gas, EGCM and Monochromator Air Purge will require additional filtration after the drying stage. This is the responsibility of the customer as part of the compressed air system installation.

Gas Requirements and Configurations

Table 13. Air compressor requirements

Equipment	Quality Specification	Pressure
Nitrogen Generator	ISO 8573-1:2010 CLASS 8.4.3	620–750 kPa (90–109 psi)
POP, EGCM, Monochromator Air Purge	ISO 8573-1:2010 CLASS 1.4.3	450–600 kPa (58–87 psi)

CAUTION

The nitrogen generator will be permanently damaged by oil vapor or aerosol from a compressor. The damage will *not* be repairable and will require replacement of the product

CAUTION

Oil-free compressors may still deliver oil (hydrocarbons) to the nitrogen generator if the inlet air is contaminated. It is essential that clean air, free of hydrocarbons and acid, is supplied to the inlet of the compressor. A three-stage filter is used between the compressor and nitrogen generator to protect the nitrogen generator from any remaining contamination.

CAUTION

Even when an oil-free compressor is used the filter unit incorporated in the nitrogen generator must be used.

Multiple Agilent 4100 MP-AES and nitrogen generator installations

If an installation of several instruments is being planned it may be worthwhile to reduce capital and maintenance costs for the compressor(s) by using fewer compressors than instruments. This saving must be weighed up against the redundancy achieved by having every instrument independent so that no single failure (except the electric power supply) disables all the instruments.

If multiple nitrogen generators and instruments are run off one compressor the free air delivery (FAD) and receiver volume specified should be multiplied by the number of instruments.

In very large installations larger nitrogen generator(s) may be used so long as the nitrogen purity is as specified in this guide.

Agilent 4100 MP-AES Gas Configurations

Your Agilent 4100 MP-AES may come with one or more Agilent accessories. Some of the accessories also require gas supplies. This section is designed to assist you with planning your gas requirements according to the system and accessories ordered so that at the time of installation you have the necessary gas supplies, and they meet the required specifications.

Shown below is a summary table detailing the various gas requirements for the Agilent 4100 MP-AES and accessories. Table 14 details nitrogen and argon gases, and the compressed air requirement, for the POP gas.

Table 14. Nitrogen and argon specifications

	Nitrogen	Nitrogen	Argon
Intended use	Plasma support gases	Purged mono	Plasma ignition gas
Purity	>99.5%	>99.95%	99%
Oxygen	< 0.5%	< 0.05%	n/a
Water	< 4ppm	< 4ppm	n/a
Required flow (SLPM)	25	10	1.5
Required pressure (kPa)	450–600	450–600	200–440

Table 15 details the compressed air requirements for the Agilent 4100 MP-AES and accessories.

Table 15. Compressed air specification for the nitrogen generator and accessories

Intended use	POP gas	Nitrogen generator plasma gas	Monochromator nitrogen generator purge	Organics	Monochromator air purge
Quality	ISO 8573-1:2010 CLASS 1.4.3	ISO 8573-1:2010 CLASS 8.4.3	ISO 8573-1:2010 CLASS 8.4.3	ISO 8573-1:2010 CLASS 1.4.3	ISO 8573-1:2010 CLASS 1.4.3
Required flow (SLPM)	25	115	115	1.5	10
Required pressure (kPa)	450–600	620–750	620–750	450–600	450–600
Max output flow (SLPM)	n/a	25	10	n/a	n/a
Output pressure (kPa)	n/a	450–600	450–600	n/a	n/a

The following pages detail some the possible 4100 MP-AES and accessory configurations along with their associated gas requirements. Use these as an example for calculating/determining your gas requirements.

Gas Requirements and Configurations

Figure 1. Agilent 4100 MP-AES, N₂ plasma gases supplied from nitrogen generator, argon gas supplied from Onboard Argon Supply, POP gas supplied from the air compressor.

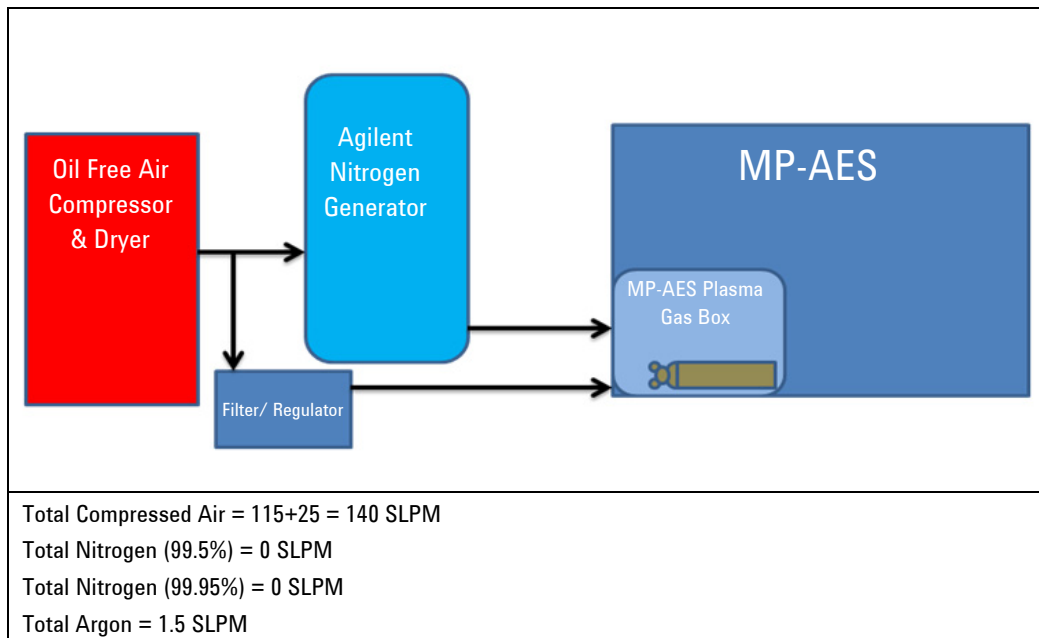
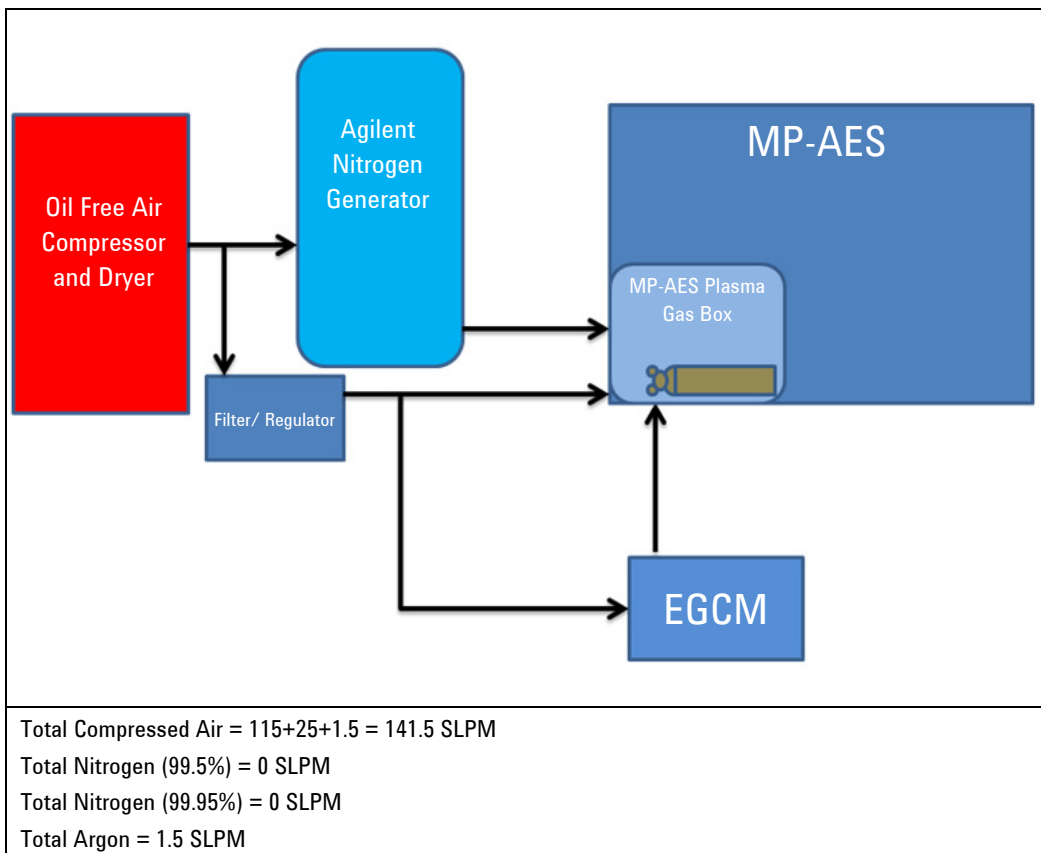

Figure 2. Agilent 4100 MP-AES, N₂ plasma gases supplied from nitrogen generator, argon gas supplied from Onboard Argon Supply, POP gas supplied from the air compressor, EGCM configured for organics analysis.



Gas Requirements and Configurations

Figure 3. Agilent 4100 MP-AES, N₂ plasma gases supplied from nitrogen generator, argon gas supplied from Onboard Argon Supply, POP gas supplied from the air compressor, EGCM configured to purge the monochromator with N₂ to allow determination of sulfur.

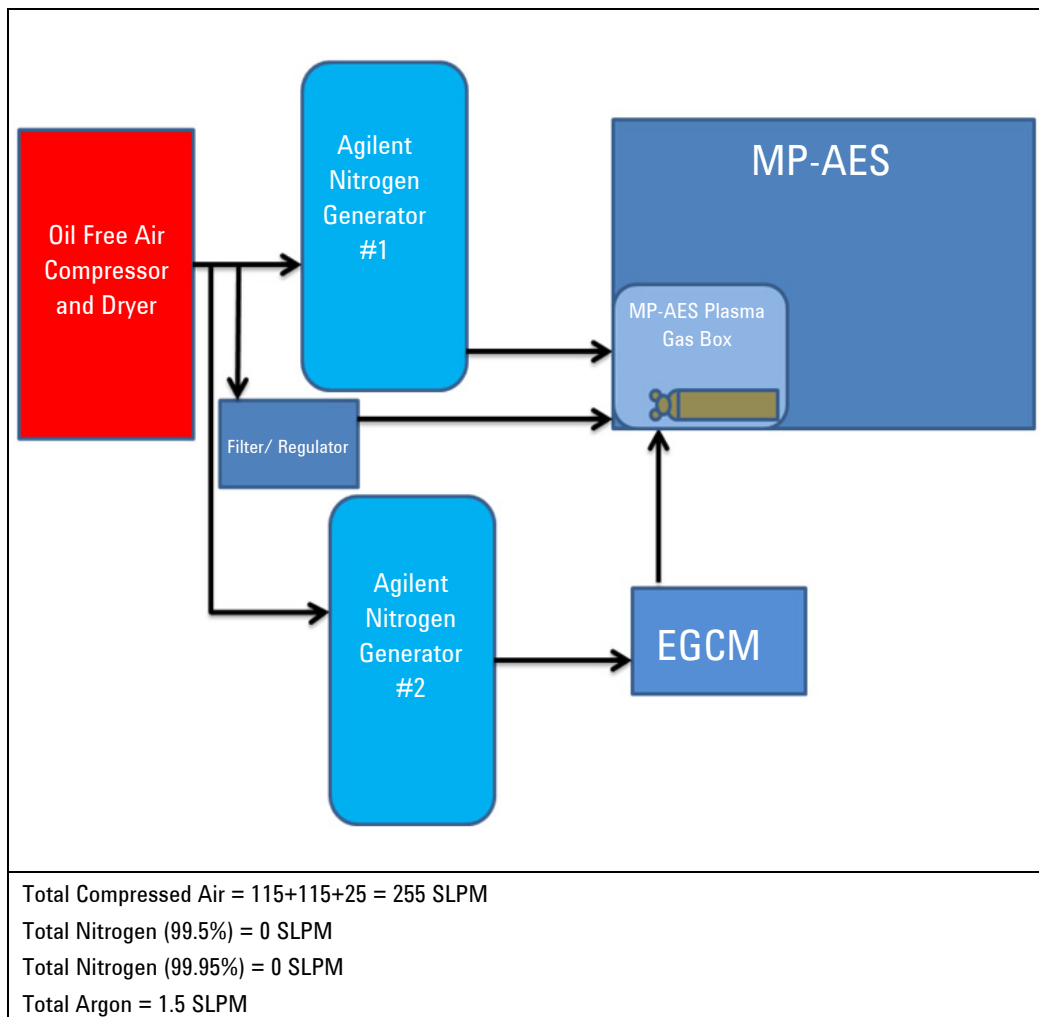
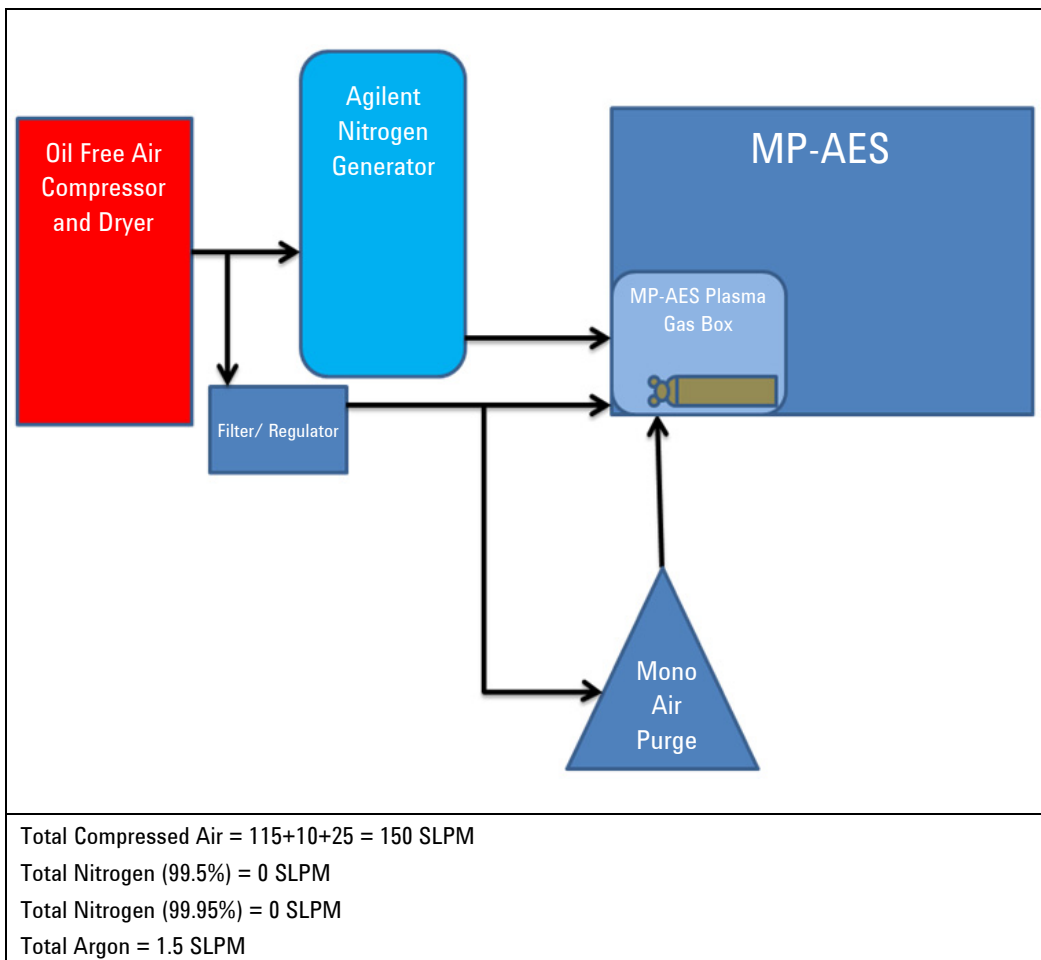

Figure 4. Agilent 4100 MP-AES, N₂ plasma gases supplied from nitrogen generator, argon gas supplied from Onboard Argon Supply, POP gas supplied from the air compressor, Monochromator Air Purge supplied from air compressor to keep the monochromator at positive pressure and exclude any dust or vapors.



Gas Requirements and Configurations

Figure 5. Agilent 4100 MP-AES, N₂ plasma gases supplied from nitrogen generator #1, argon gas supplied from Onboard Argon Supply, POP gas supplied from the air compressor, EGCM configured to purge the monochromator with N₂ from nitrogen generator #2 and to supply air from the air compressor for analysis of organics.

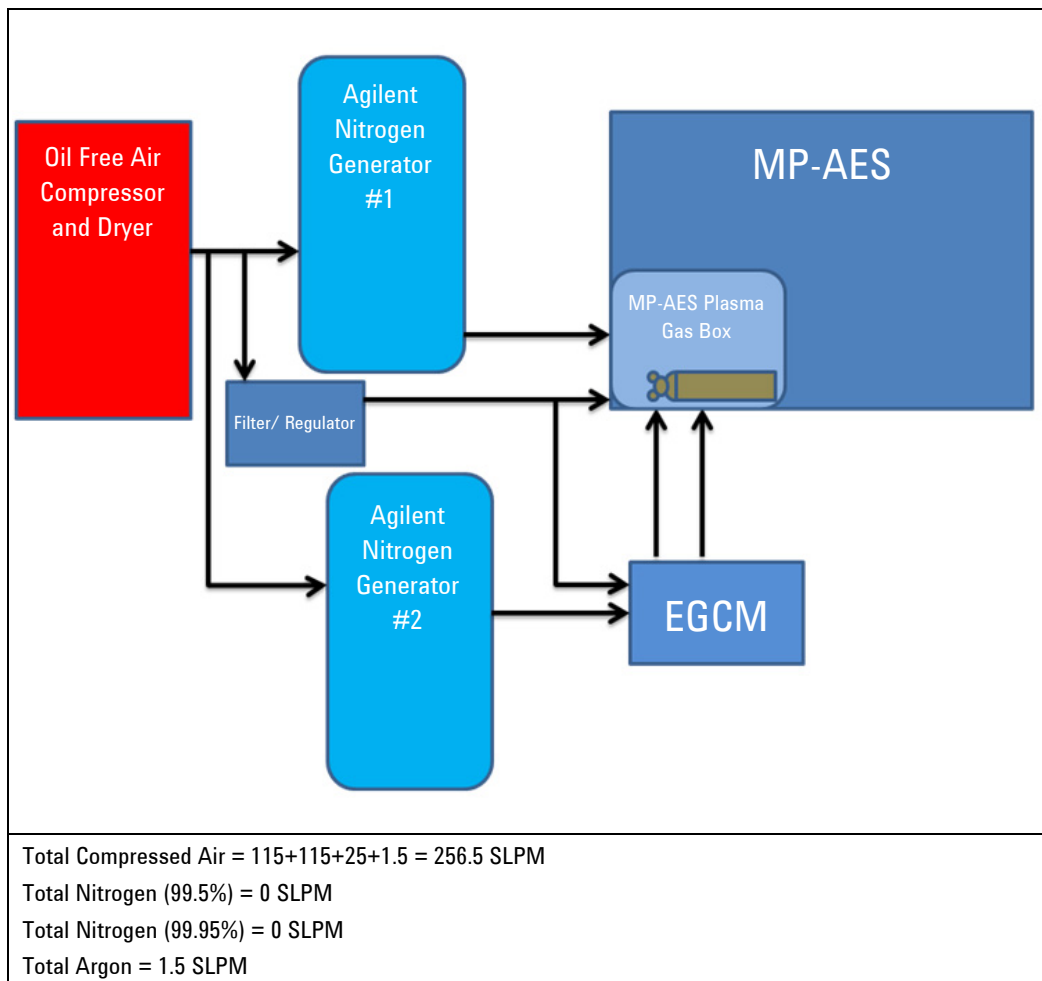
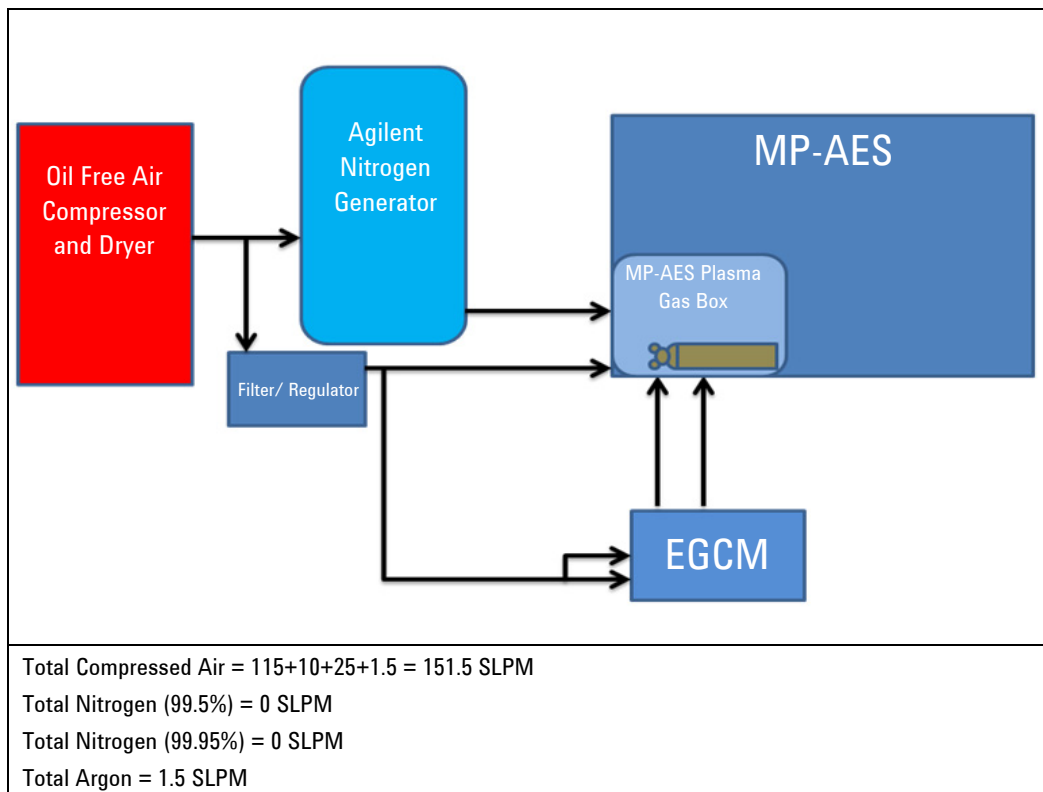

Figure 6. Agilent 4100 MP-AES, N₂ plasma gases supplied from nitrogen generator, argon gas supplied from Onboard Argon Supply, POP gas supplied from the air compressor, EGCM configured to purge the monochromator with air from the air compressor and to provide air for analysis of organics.



Gas Requirements and Configurations

Figure 7. Agilent 4100 MP-AES, N₂ plasma gases supplied from cylinder/Dewar system, argon gas supplied from Onboard Argon Supply, POP gas supplied from the air compressor,

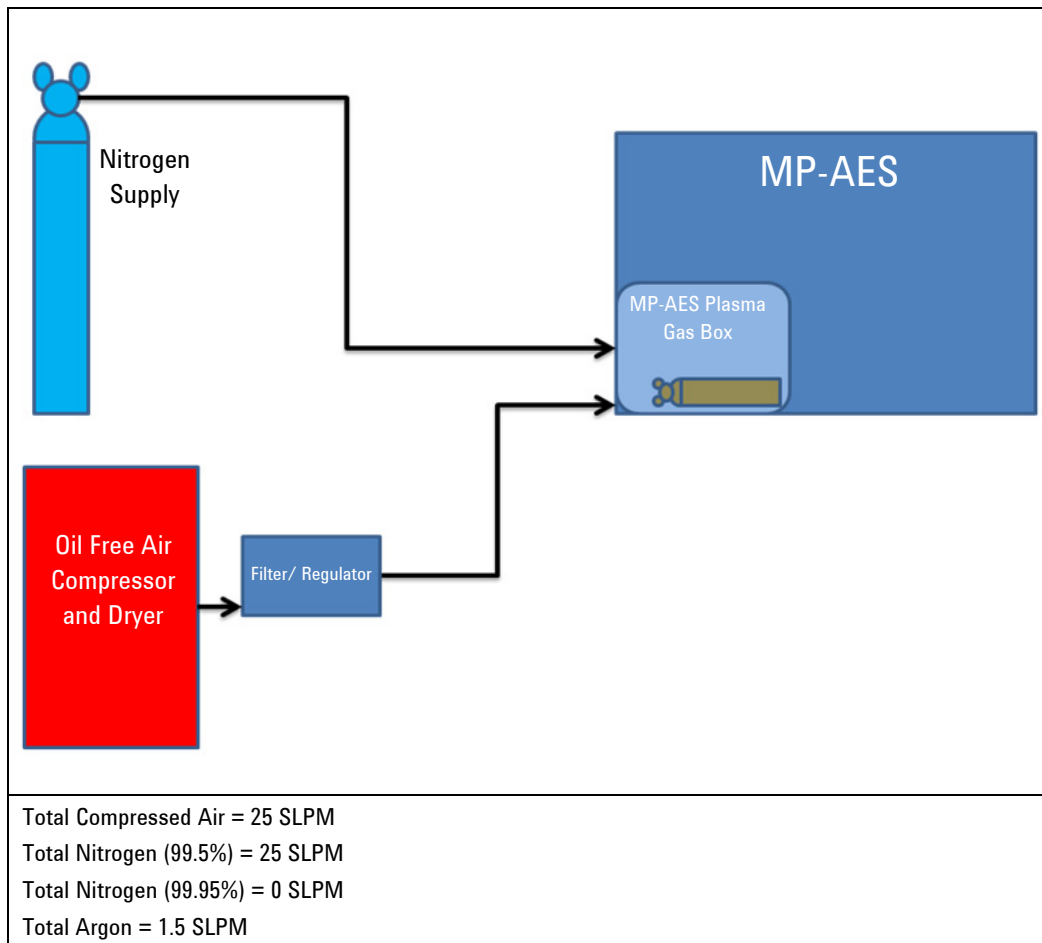
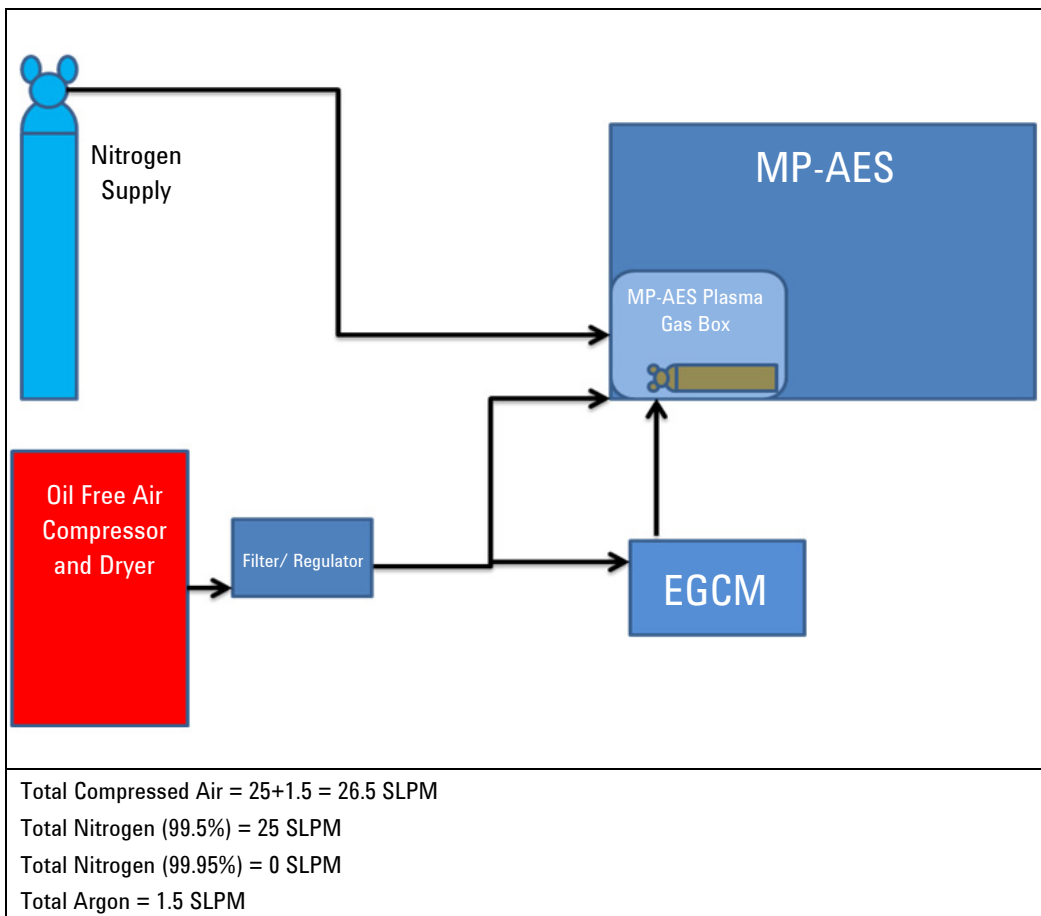

Figure 8. Agilent 4100 MP-AES, N₂ plasma gases supplied from cylinder/Dewar system, argon gas supplied from Onboard Argon Supply, POP gas supplied from the air compressor, EGCM configured to supply air from the air compressor for organics analysis.



Gas Requirements and Configurations

Figure 9. Agilent 4100 MP-AES, N₂ plasma gases supplied from cylinder/Dewar system, argon gas supplied from Onboard Argon Supply, POP gas supplied from the air compressor. EGCM configured to purge the monochromator with nitrogen.

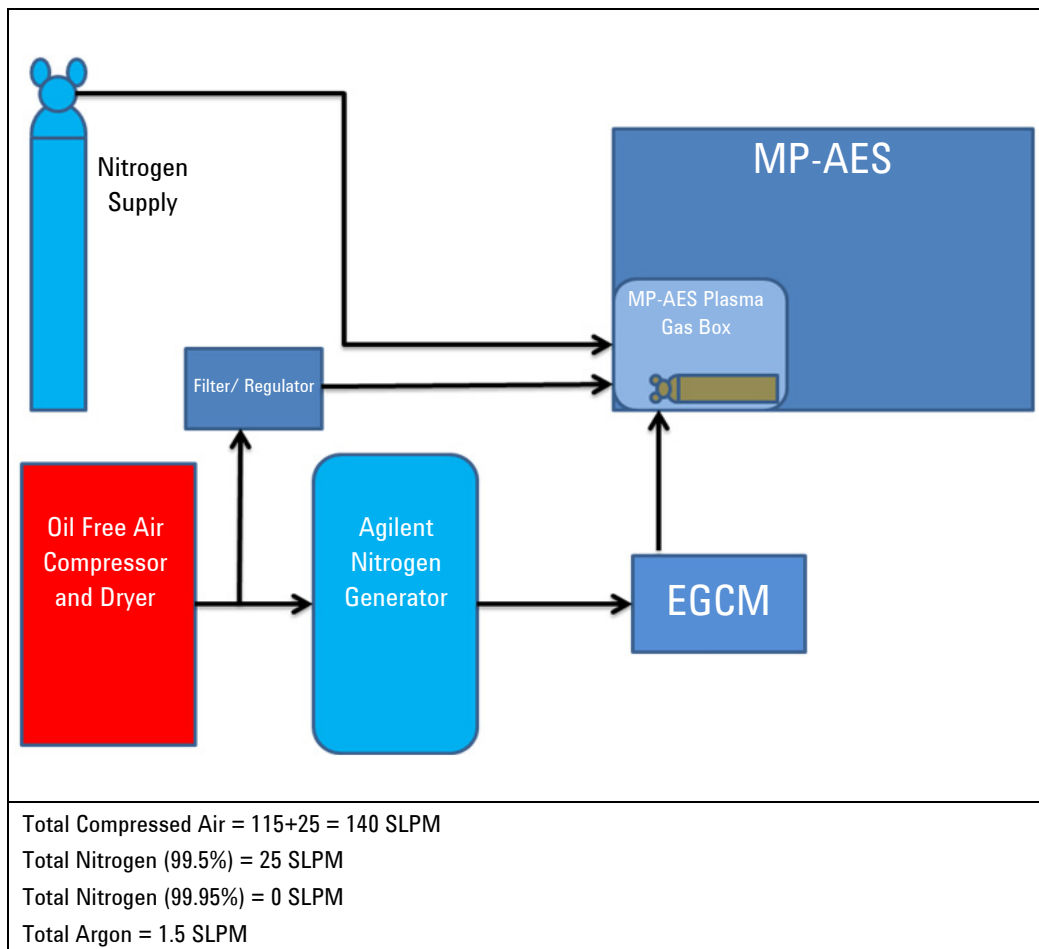
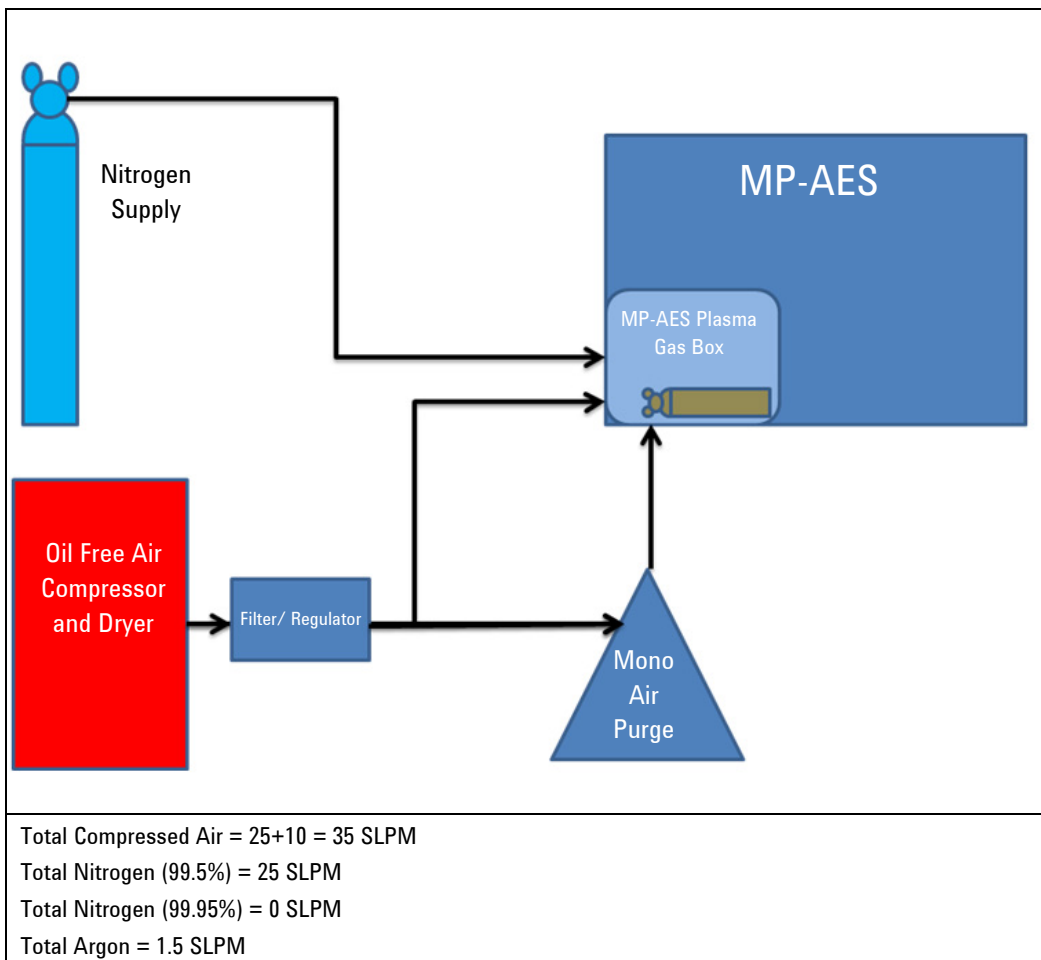
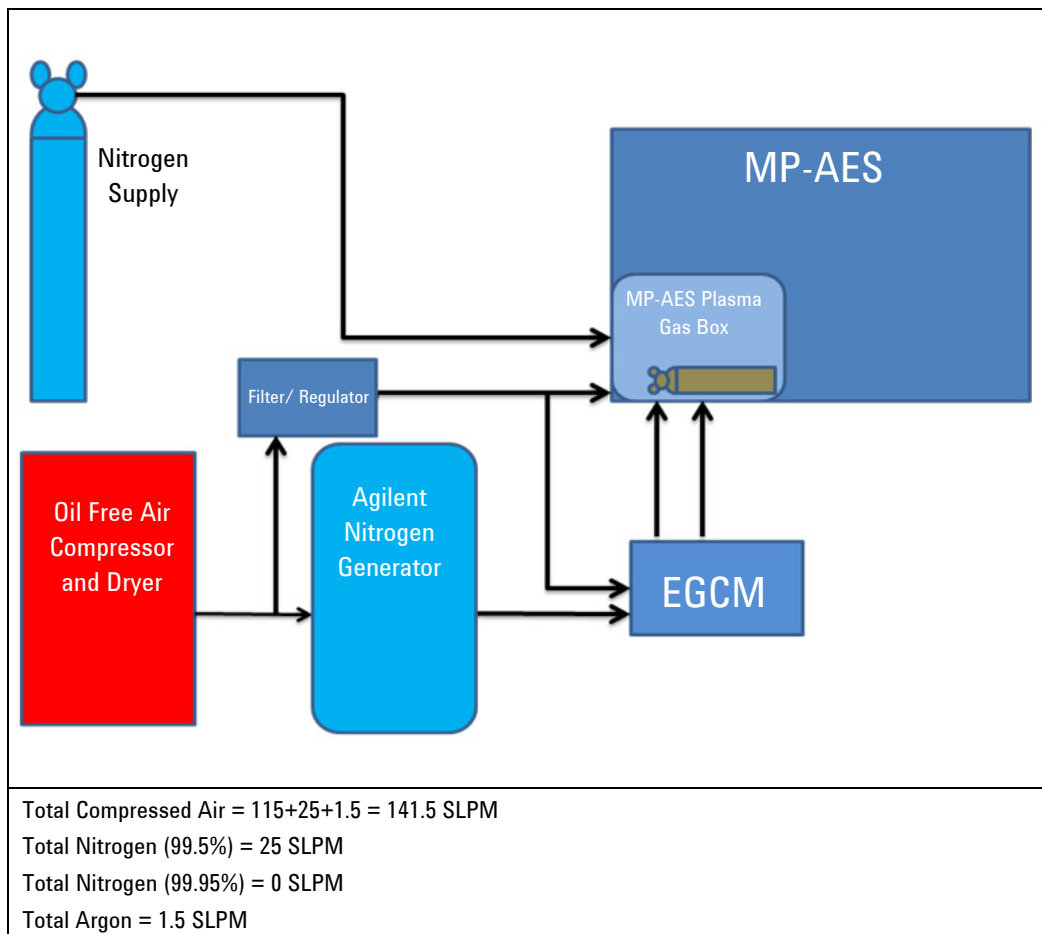

Figure 10. Agilent 4100 MP-AES, N₂ plasma gases supplied from cylinder/Dewar system, argon gas supplied from Onboard Argon Supply, POP gas supplied from the air compressor. Air supplied to the Monochromator Air Purge from the air compressor.



Gas Requirements and Configurations

Figure 11. 4100 MP-AES, N₂ plasma gases supplied from cylinder/Dewar system, argon gas supplied from Onboard Argon Supply, POP gas supplied from the air compressor, EGCM configured to purge the monochromator with nitrogen from a nitrogen generator and provide air from the air compressor for organics analysis.



This page is intentionally left blank.

In This Guide

The guide describes the following:

- General Information and Safety Practices and Hazards
- Specifications
- Installation Requirements
- Agilent 4100 MP-AES Gas Requirements

© Agilent Technologies 2011

Printed in USA

08/11



G8000-90001

Issue 1



Agilent Technologies