



Flagship Balances from OHAUS

When laboratory work and research requires accuracy to the hundred-thousandth, there is simply no room for error. The Explorer series of semi-micro balances has been designed with the technology to ensure that your very specific weighing results are accurate. Sophisticated laboratories requiring accuracy and looking for innovative technology to obtain measurement results can find both in Explorer semi-micro balances.

Unique Features Include:

- The semi-micro Explorer series, which includes models with capacities up to 220 g and resolutions up to 0.01 mg, has been designed to use a High Speed Single Module weighing cell to ensure the accuracy of results. To minimize weighing errors and ensure accurate measurements, AutoCal™ utilizes two internal weights to perform a linear calibration.
- Features such as four-level user management with password protection, and un-editable system log plus a high level of configurability make Explorer balances well suited for regulated applications.
- A detachable terminal with a large color touchscreen, programmable IR sensors, optional built-in Ionizer and automatic doors, and a frameless draftshield make Explorer balances easy and convenient to use.

EXPLORER[®] Semi-Micro Balances

Intelligent Performance for Applications Requiring Extreme Accuracy

Explorer semi-micro balances offer capacities ranging from 52 g–220g with a readability of 0.01 mg. Superior craftsmanship, a High Speed Single Module weighing cell and a variety of advanced features make Explorer balances well suited for even the most complex weighing tasks.

Weighing Performance

OHAUS' signature AutoCal™ internal calibration system ensures the balance is always ready for use and eliminates the need for manual routine calibration. Explorer's internal calibration mechanism uses multiple weights and adjusts the balance at several points within the weighing range; this results in lower measurement uncertainty than a simple span calibration. Additionally, Explorer balances feature a built-in Repeatability Test, which helps evaluate the balance's performance and aids in determining a suitable minimum weight for applications requiring high accuracy.

Connectivity

Explorer balances include a series of communication interfaces including RS-232, USB, and Ethernet, allowing accessories such as RFID readers, printers and barcode scanners to be connected to the balance. A simple yet complete communication protocol allows Explorer balances to be easily connected to a PC or integrated with larger systems.

Data Management

Explorer balances are equipped with internal databases, which can be used to store, manage, and retrieve application and system data. An internal weighing mode library allows saving and loading of weighing mode configurations. The system event log records up to 5000 changes to the balance's settings, calibrations and adjustments, and user access. System logs can be exported as a non-editable PDF file and saved onto a USB memory stick. A built-in real time clock ensures that the data captured is contemporaneous.

User Management

The user management system allows a system administrator to create up to 110 users and assign them to 1 of 4 pre-existing groups with varying access rights to the balance and enforce password protection ensuring data integrity in a multi-user environment.



User Profiles			
#	User Name	Group	Password
>> 1	Admin	Administrator	
2	Jeremy	Supervisor	*****
3	Jonny	Operator	*****
4	Adam	Log Viewer	*****

New Edit Delete Return to Application

Ingenious Construction Designed to Enhance Usability

The sleek Explorer semi-micro balance has been designed and constructed to provide a modern weighing experience as well as to bolster accuracy.

Operator Experience

Among the features that enhance the operator experience are:

- Color touchscreen display
- Four programmable touchless sensors allow the operator to perform common functions and commands with a swipe of the hand
- Modular design in which the base and display can be separated to allow the balance to fit ideally on the lab bench.
- Antistatic coated glass helps dissipate static charges in the weighing chamber which could adversely affect the weighing results



Auto-Doors

The automatic door feature, available on certain models, allows access to the weighing chamber without the need to touch the draftshield door. Placement of samples is achieved in one swift motion, eliminating the repetition of picking up and putting down samples due to a lack of free hands.

The automatic doors are also more than a user-friendly feature; they minimize vibrations caused by manual operation that can affect weighing results.

Ionizer

The built-in ionizer, included in Explorer automatic door models, generates bipolar ions continuously from positive and negative discharge electrodes and directs the ionized air onto the charged body to eliminate static electricity. These charges can build up in the weighing chamber and alter weighing results by as much as several milligrams.



Outline Dimensions

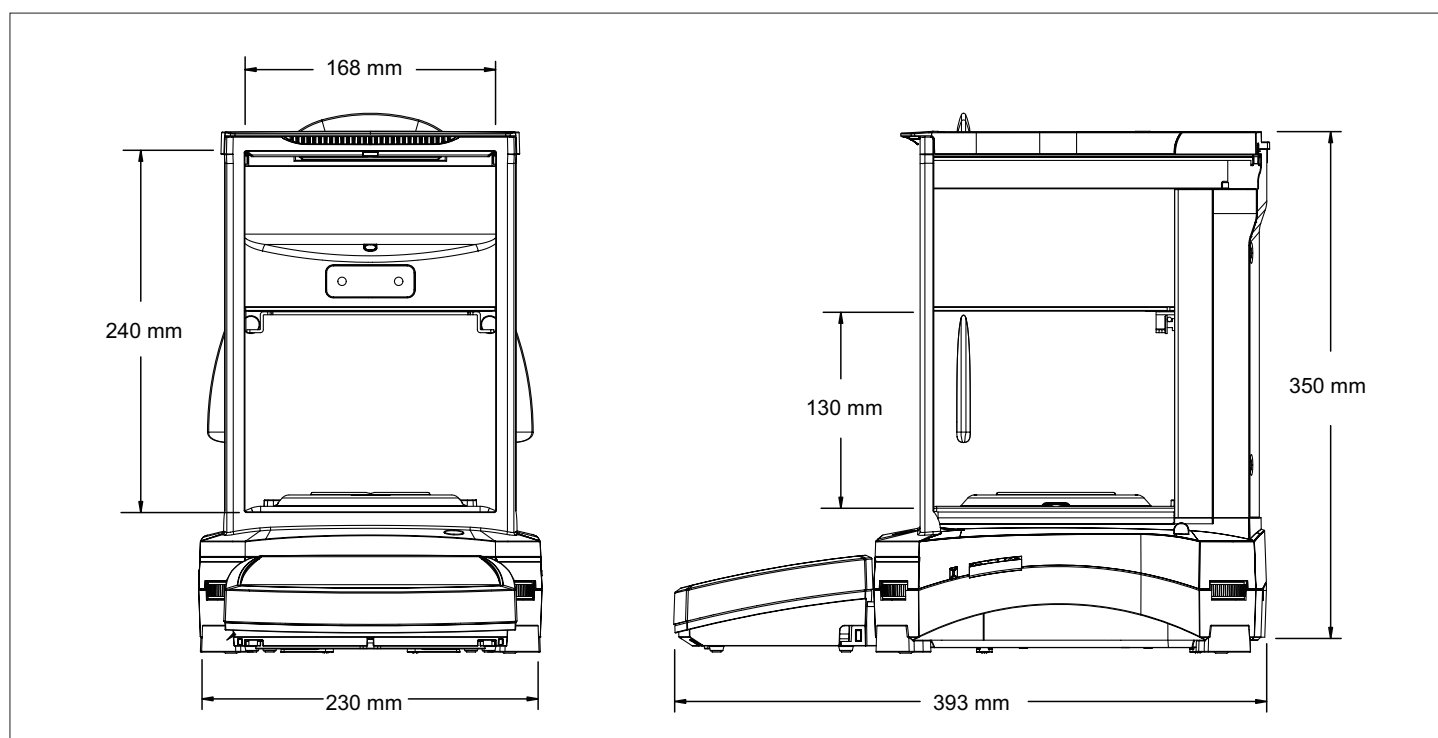

EXPLORER® Semi-Micro Balances

MODEL	EX125D*	EX125	EX225D*	EX225D/AD*	EX225/AD	EX125DM*	EX125M	EX225DM*	EX225DM/ AD*	EX225M/AD
Maximum Capacity (Fine range/Full range)	52 g / 120 g	120 g	120 g/220 g	120 g/220 g	220 g	52 g / 120 g	120 g	120 g/220 g	120 g/220 g	220 g
Readability, Fine Range	0.01 mg	0.01 mg	0.01 mg	0.01 mg	0.01 mg	0.01 mg	0.01 mg	0.01 mg	0.01 mg	0.01 mg
Readability, Full Load	0.1 mg		0.1 mg	0.1 mg		0.1 mg		0.1 mg	0.1 mg	
Verification Interval* e (g)	Non-approved model						0.001			
Accuracy class	Non-approved model						I			
Min (g)	Non-approved model						0.001			
Repeatability, 10 g (sd.)	0.01 mg	0.01 mg	0.01 mg	0.01 mg	0.01 mg	0.01 mg	0.01 mg	0.01 mg	0.01 mg	0.01 mg
Repeatability, Fine Range	0.02 mg	0.02 mg	0.02 mg	0.02 mg	0.03 mg	0.02 mg	0.02 mg	0.02 mg	0.02 mg	0.03 mg
Repeatability, Full Load	0.1 mg		0.1 mg	0.1 mg		0.1 mg		0.1 mg	0.1 mg	
Linearity Deviation, 10g	±0.06 mg					±0.06 mg				
Linearity Deviation, Full Range	±0.1 mg					±0.1 mg				
Stabilization time, Fine Range	8 s	8 s	8 s	8 s	8 s	8 s	8 s	8 s	8 s	8 s
Stabilization time, Full Load	2 s		2 s	2 s		2 s		2 s	2 s	
Minimum Weight (U = 1%, k = 2)	2 mg					2 mg				
USP Minimum Weight	20 mg					20 mg				
Optimized USP Minimum Weight (SRP ≤ 0.41d)**	9 mg					9 mg				
AutoCalTM	Standard Automatic Calibration System					Standard Automatic Calibration System				
- Temperature Differ	1.5 °C					1.5 °C				
- Time interval	3 h					3 h				
Sensitivity Temp. Drift	0.5 ppm / °C					0.5 ppm / °C				
Automatic Doors	N/A	N/A	N/A	Standard		N/A	N/A	N/A	Standard	
Built-in Ionizer	N/A	N/A	N/A	Standard		N/A	N/A	N/A	Standard	

* D stands for dual range, i.e. the capacity of fine range is 52g and the maximum capacity is 120g.

** According to USP41, repeatability is satisfactory if two times the standard deviation of the weighted value divided by the minimum weight does not exceed 0.10%. The standard deviation obtained is less than 0.41d, where d is the scale interval, replace this standard deviation with 0.41d. In this case, the repeatability is satisfactory if 2*0.41d divide by minimum weight is less than 0.10%.

Approvals

- **Metrology:** OIML R76, EN 45501 (Class I, nmax 220000)
- **Product Safety:** EN 61010-1, IEC 61010-1
- **Electromagnetic Compatibility:** IEC 61326-1, EN61326-1 (Class B emissions, Industrial immunity)

Accessories

ION-100A - Ionizer	30130303
Density Kit for Solids	80253384
Sinker Glass for Density Determination.....	83034024
Full-featured Impact Printer SF40A	30064202
SF40A Paper roll (57,5mm 2pcs)	12120799
SF40A Ink ribbon cassette	12120798
RS232 cable, PC 9 Pin.....	00410024
USB cable (type A to B)	83021085
Ethernet interface	83021082
Terminal extension cable (2 m)	83021083
Secondary display PAD7	80251396
Security device (Cable & lock)	80850000
Security device (Laptop lock)	80850043
Terminal in-use cover	83033633
Dust cover	30093334
Grid Pan for Air Filter Weighing	30298582

OHAUS Europe GmbH
 Im Langacher 44
 8606 Greifensee
 Switzerland
 e-mail: ssc@ohaus.com
 Tel: 0041 22 567 53 19
 e-mail: tsc@ohaus.com
 Tel: 0041 22 567 53 20

www.ohaus.com

OHAUS Corporation is an ISO 9001:2008 manufacturer

ISO 9001:2008
 Registered Quality Management System

CH16B042

